

INTERFACE CONTROL DOCUMENT

1 SEE USERS MANUAL FOR DETAILED INSTRUCTIONS.

2 INSTALL HIGH-G BRACKETS OVER IDT BATTERY CLAMPS.

REVISIONS					
ZONE	REV.	ECO #	DESCRIPTION	DATE	APPROVED
	A	ECO-0085	INITIAL RELEASE FOR PRODUCTION.	6/26/2017	B. MOAK
	B	ECO-0123	ADDED VIEW ON SHEET TWO WITH BATTERY CONNECTED	8/2/2017	B. MOAK
	C	ECO-0473	REVISED OVERALL DOCUMENT. ADDED VIEWS FOR HIGH-G BRACKET OPTION. ADDED PINOUTS FOR LEMO AND USB-C CONNECTORS.	6/12/2019	C. VIDAMO

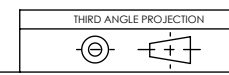
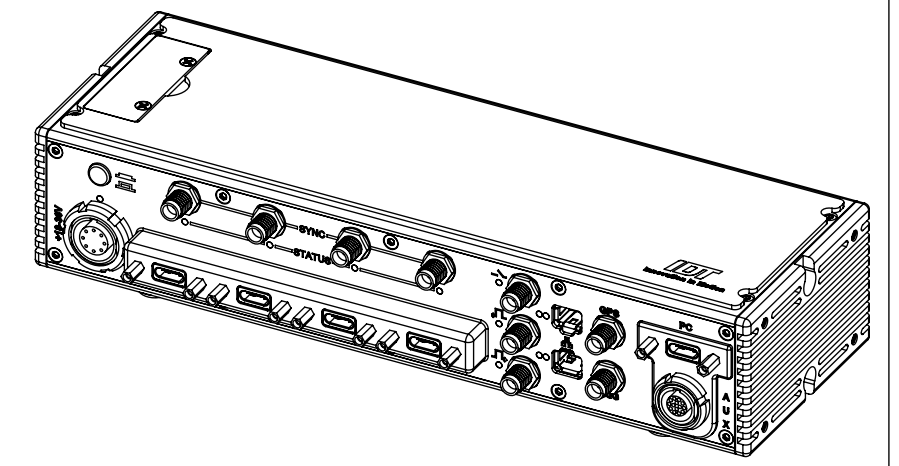
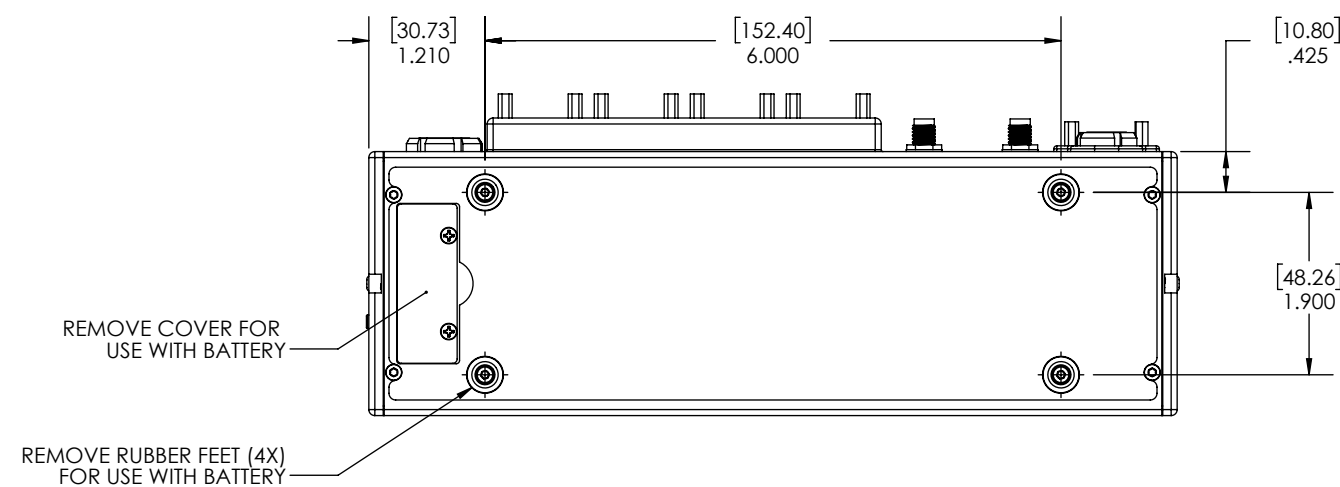
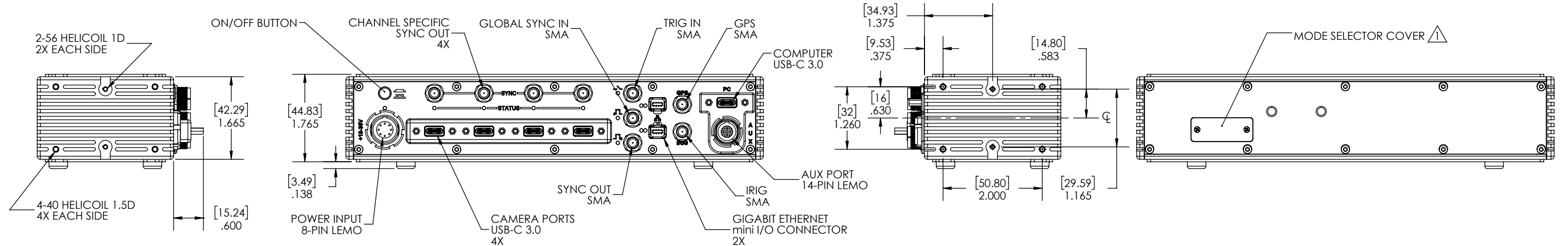
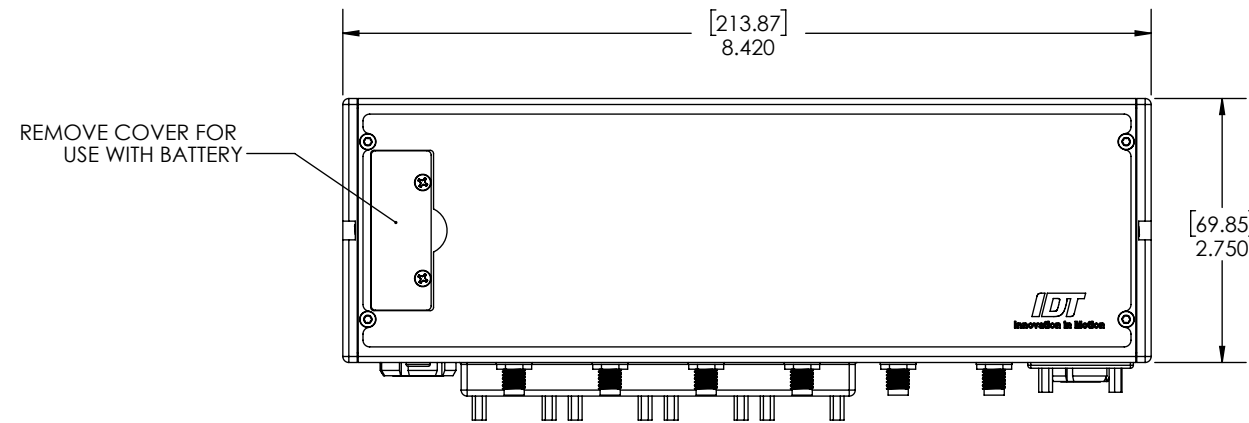

PROPRIETARY AND CONFIDENTIAL <small>THE INFORMATION CONTAINED IN THIS DRAWING IS THE SOLE PROPERTY OF INTEGRATED DESIGN TOOLS, INC. ANY REPRODUCTION IN PART OR AS A WHOLE WITHOUT THE WRITTEN PERMISSION OF INTEGRATED DESIGN TOOLS, INC. IS PROHIBITED.</small>	PROJECT NAME: TC30 HUB	DRAWN: C. VIDAMO DATE: 06/12/2019	INTEGRATED DESIGN TOOLS, INC. 1 WEST MOUNTAIN STREET SUITE 3 PASADENA, CA 91103
	UNLESS OTHERWISE SPECIFIED: DIMENSIONS ARE IN INCHES TOLERANCES ON: FRACTIONAL DECIMAL ANGULAR ± 1/16 .X ± .03 ± 1° .XX ± .01 .XXX ± .005	CHECKED: B. MOAK DATE: 06/12/2019 MECH. ENGINEER: B. MOAK DATE: 06/12/2019 ELECTRICAL ENGINEER: OPERATIONS MANAGER: PROGRAM MANAGER:	TITLE: TC30 HUB, INTERFACE CONTROL DOCUMENT (ICD)
IDT	DO NOT SCALE DRAWING	REV C	SHEET 1 OF 2

WITH SINGLE BATTERY CONNECTED

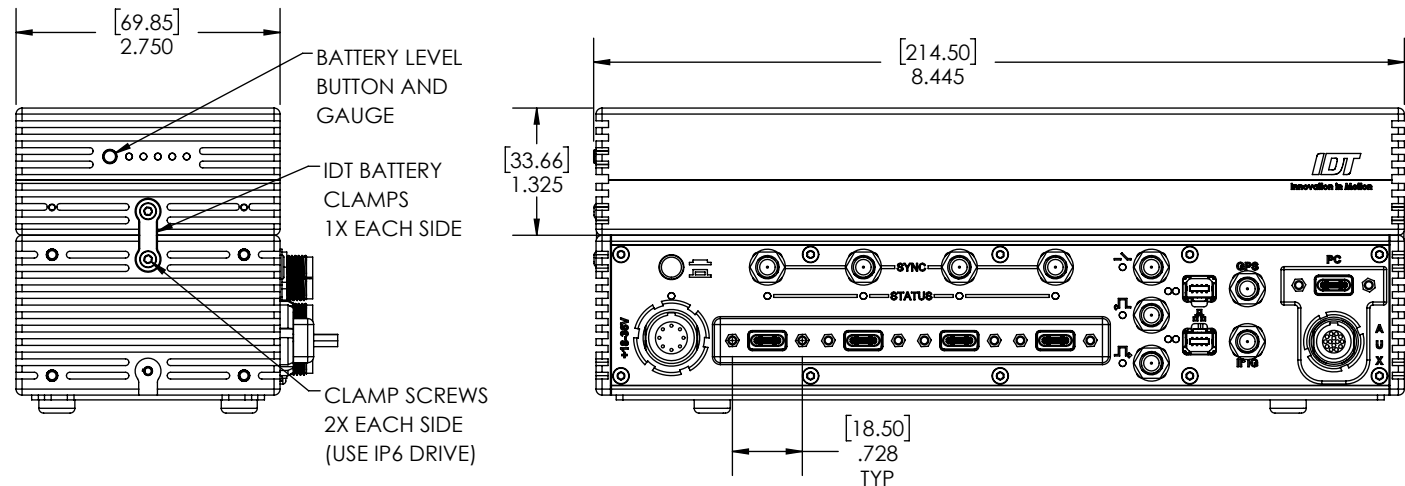

WITH SINGLE BATTERY CONNECTED AND HIGH-G BRACKETS

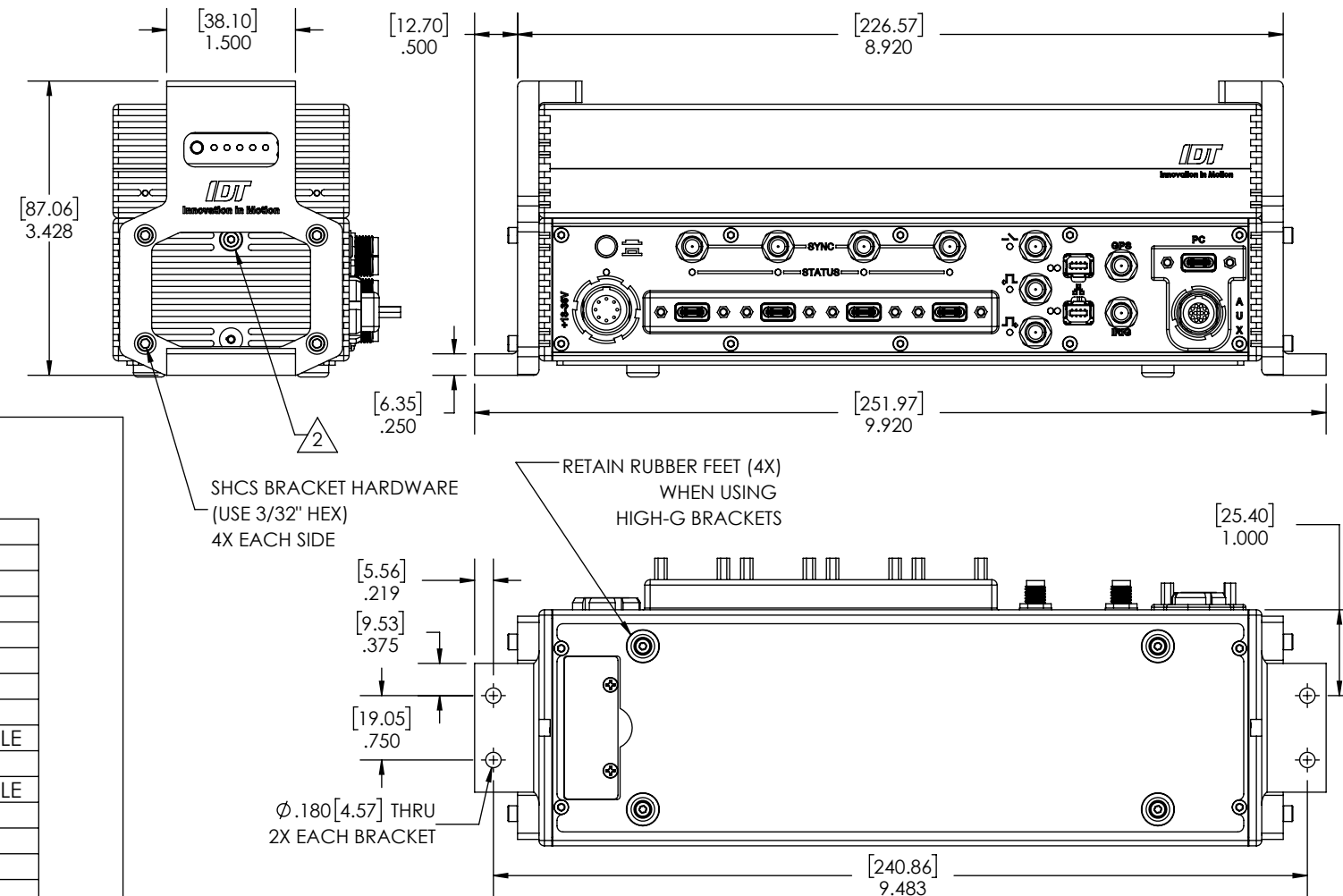

FOR CONNECTOR ELECTRICAL SPECIFICATION REFERENCE ONLY

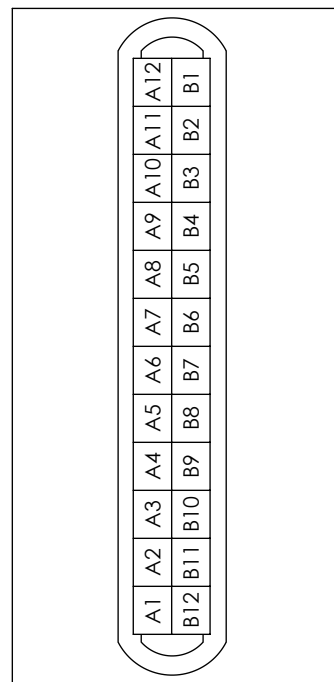

USB-C 3.0 CONNECTOR CAMERA PORTS		
PIN	SIGNAL	TECHNICAL DESCRIPTION
A1	GND	GROUND, DRAIN
A2	MCT 6 / ETH 7	100 Ω ± 15%, GIGABIT ETHERNET (1000BaseT)
A3	MCT 7 / ETH 8	100 Ω ± 15%, GIGABIT ETHERNET (1000BaseT)
A4	+ CAM POWER	10 VDC
A5	READY OUT	TTL 5V, 10mA MAX
A6	SYNC IN	2.7 kΩ ± 10% SWITCH CLOSURE (TTL) 5V AND CMOS LEVEL COMPATIBLE
A7	SYNC OUT	TTL 5V, 10mA MAX
A8	TRIG IN	2.7 kΩ ± 10% SWITCH CLOSURE (TTL) 5V AND CMOS LEVEL COMPATIBLE
A9	+ CAM POWER	10 VDC
A10	MCT 3 / ETH 6	100 Ω ± 15%, GIGABIT ETHERNET (1000BaseT)
A11	MCT 2 / ETH 3	100 Ω ± 15%, GIGABIT ETHERNET (1000BaseT)
A12	GND	GROUND, DRAIN
B1	GND	GROUND, DRAIN
B2	MCT4 / ETH 4	100 Ω ± 15%, GIGABIT ETHERNET (1000BaseT)
B3	MCT 5 / ETH 5	100 Ω ± 15%, GIGABIT ETHERNET (1000BaseT)
B4	+ CAM POWER	10 VDC
B5	READY OUT	TTL 5V, 10mA MAX
B6	SYNC IN	2.7 kΩ ± 10% SWITCH CLOSURE (TTL) 5V AND CMOS LEVEL COMPATIBLE
B7	SYNC OUT	TTL 5V, 10mA MAX
B8	TRIG IN	2.7 kΩ ± 10% SWITCH CLOSURE (TTL) 5V AND CMOS LEVEL COMPATIBLE
B9	+ CAM POWER	10 VDC
B10	MCT 1 / ETH 2	100 Ω ± 15%, GIGABIT ETHERNET (1000BaseT)
B11	MCT 0 / ETH 1	100 Ω ± 15%, GIGABIT ETHERNET (1000BaseT)
B12	GND	GROUND, DRAIN

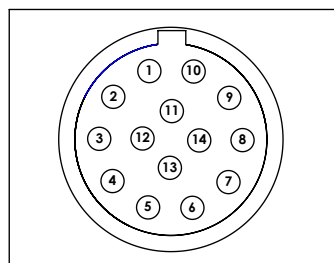

LEMO CONNECTOR B-SERIES ECG.1B.314.CLV														
PIN	1	2	3	4	5	6	7	8	9	10	11	12	13	14
SIGNAL	TRIG IN DIFF +	TRIG IN DIFF -	ISOLATED GND	ISOLATED GND	SYNC IN DIFF +	SYNC IN DIFF -	SYNC OUT DIFF +	SYNC OUT DIFF -	GND	READY OUT	+7.5 VDC	+7.5 VDC	GND	GND

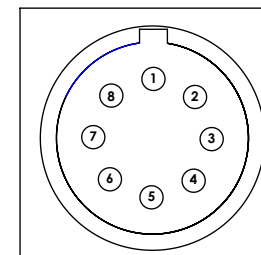

LEMO CONNECTOR B-SERIES ECG.2B.308.CLV	
PIN	SIGNAL
1	
2	POWER INPUT +VDC
3	
4	
5	POWER GROUND
6	
7	
8	

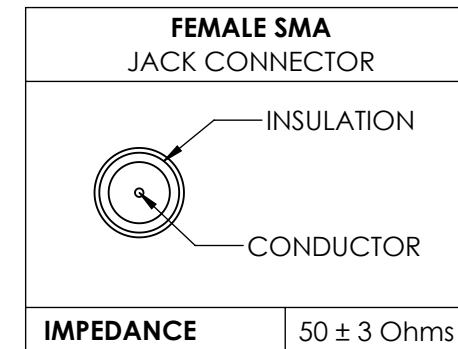

IMPEDANCE	50 ± 3 Ohms
-----------	-------------

PROPRIETARY AND CONFIDENTIAL
THE INFORMATION CONTAINED IN THIS DRAWING IS THE SOLE PROPERTY OF INTEGRATED DESIGN TOOLS, INC. ANY REPRODUCTION IN PART OR AS A WHOLE WITHOUT THE WRITTEN PERMISSION OF INTEGRATED DESIGN TOOLS, INC. IS PROHIBITED.

PROJECT NAME: **TC30 HUB**

UNLESS OTHERWISE SPECIFIED: DIMENSIONS ARE IN INCHES TOLERANCES ON:
 FRACTIONAL DECIMAL ANGULAR ± 1/16 X ± .03 ± 1°
 .XX ± .01
 .XXX ± .005

INTEGRATED DESIGN TOOLS, INC
1 WEST MOUNTAIN STREET SUITE 3 PASADENA, CA 91103

TITLE: **TC30 HUB, INTERFACE CONTROL DOCUMENT (ICD)**

DO NOT SCALE DRAWING

SCALE: 1:2 DATE: 6/13/2019 SHEET 2 OF 2

